

Berger's 7mm VLD Bullets

Part 1: Properties and Test Results

Bryan Litz
bsl135@yahoo.com

Introduction

Berger currently offers two bullets in 7mm: 168 grain and 180 grain VLD's. The versatility of these two bullets extends from big game hunting to long range benchrest competition and everything in between including long range NRA prone and F-class score shooting. The 7mm 180 grain VLD is of particular interest because of its stellar advertised BC. In part 1 of this two part series, I'll describe the ballistic properties and performance of these two bullets in a general sense, meaning the information applies to all types of shooting that these bullets might be used for. In part 2, I'll explore the ballistic properties and performance of the two bullets from the perspective of long range NRA prone slow fire competition.

Design

Figures 1 and 2 show dimensioned drawings of the bullets used for the ballistic coefficient test firing. Note the very aggressive secant ogive profile of the

Berger 7mm 168 grain VLD

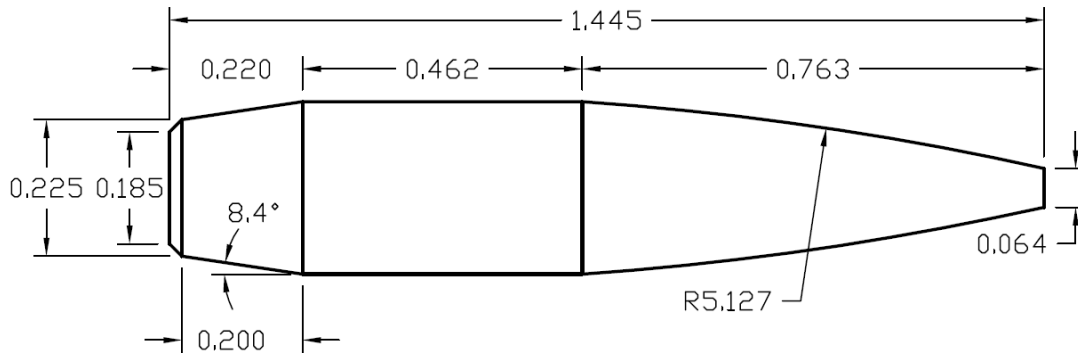

Dimensions taken from Lot#899

Bullet Properties	Test Equipment
Sample Size: 5	Velocity Range: 2900 - 1900 fps
Weight: 168 grains	Barrel: Broughton
Ogive Radius: 18.1 calibers	Twist rate: 1 turn in 8.7 in
Rt/R: 0.57	Bore/Groove: 0.2633"/ 0.284"

Figure 1. Bullet dimensions, properties, and test equipment.

VLD design. This design feature represents a compromise that many shooters know all too well. The long radius secant ogive is great for drag reduction;

however the grouping potential of VLD bullets is known to be very sensitive to seating depth.

When viewed side by side, it's very clear that the boat-tail and ogive of the two bullets are very similar. The only design difference between them is the length of the bearing surface. The bearing surface of the 180 grain bullet is 0.079" longer than the 168 grain bullet, and the overall length is 0.080" longer. Some minor differences are apparent from the drawings. For example, there is a 0.7 degree difference in boat-tail angle, a 0.001" difference in ogive length, a 0.4 caliber difference in ogive radius, and a 0.005" difference in meplat diameter. It's important to point out that the dimensions on these drawings come from my measurements of the given lot numbers. The measurements are made on a lathe with a dial indicator, and I don't claim that they're perfect. The tolerances of the dimensions is not important to the performance of the bullets, I only bring it up to clarify that my measurement of BC is tied to this particular lot number, with these dimensions.

The property that's most likely to vary for different lots of bullets is the meplat diameter. Near the end of the article is a table showing how you can expect the BC to vary for different meplat diameters. My test results are valid for the meplat diameter shown in the drawings, which is the 'nominal' value for the lot tested.

Berger 7mm 180 grain VLD

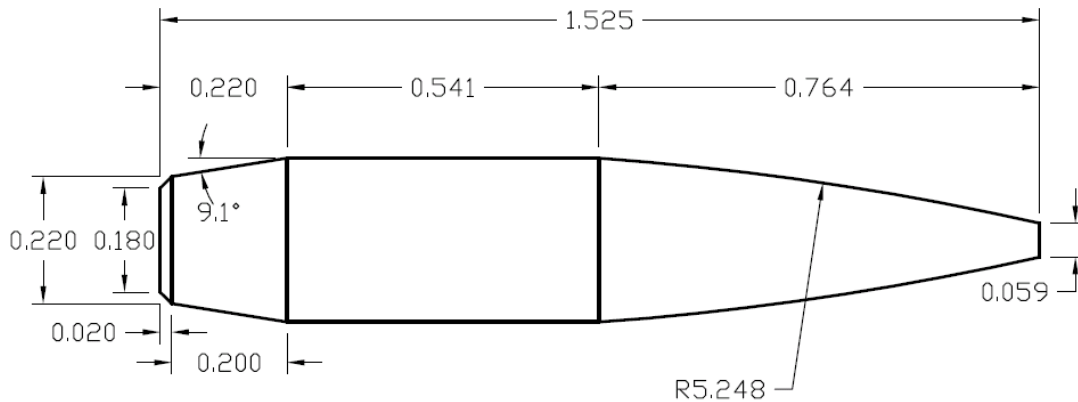

Dimensions taken from Lot#341

Bullet Properties		Test Equipment	
Sample Size:	17	Velocity Range:	2900 fps-1700 fps
Weight:	180 grains	Barrel:	Broughton
Ogive Radius:	18.5 calibers	Twist rate:	1 turn in 8.7 in
Rt/R:	0.54	Bore/Groove:	0.2633"/ 0.284"

The observation that both of these bullets have similar ogive and boat-tail designs indicates that they should have similar form factors. They have different

length bearing surfaces, but of all the parameters of bullet design, the bearing surface length has the least influence on form factor. The three major components of aerodynamic drag on a bullet are: (shock) wave drag, base drag, and skin friction drag. Wave drag makes up most of the drag, and is affected by the ogive shape, including meplat diameter. Base drag is the second most important component of drag and can be reduced with a properly designed boat-tail. Skin friction drag is the least important component of drag, and is proportional to the wetted area of the bullet. The differences between the two bullets that would affect the form factor the most are the meplat diameter and bearing surface length. The form factor of the longer 180 grain bullet is improved by having a smaller meplat diameter than the 168 grain bullet¹, but the added length increases the wetted area and skin friction drag. The offsetting effects result in very similar form factors for the two bullets.

The 180 grain VLD advertises a G1 BC of 0.682 lb/in². This bullet used to come with an advertised G1 BC of 0.698 lb/in² until a couple years ago when Berger reduced it. No design changes were made to the bullet; it was simply an adjustment to the advertised BC. How close is the new advertised G1 BC (0.682 lb/in²) to the actual *measured* G1 BC? Read on.

Stability

Stability becomes a concern for longer than average bullets such as these 7mm VLD's. The obvious question is: what rate of twist is required to properly stabilize the bullets? Manufacturers typically provide this information on the bullet boxes. Berger recommends a 1:10" twist for the 168 grain VLD, and 1:9" twist for the 180 grain VLD. Going with the manufacturers recommended twist is a safe approach, as they tend to advertise this number conservatively. These manufacturer supplied 'conservative' numbers might satisfy the less curious crowd of shooters, but those reading this article are probably interested in more detail. To examine the stability characteristics of these bullets, we turn to Don Miller's twist rule, which has appeared in these pages for several years.

Shooters are always interested in how precision is affected by stability. Is there an *optimal* twist rate for a particular bullet? Precision is affected by twist rate and stability, but not how you might think.

I'll provide a short review of the gyroscopic stability factor (Sg) and what it means. If you're interested in more details, you can refer to some past issues of PS with articles by Don Miller **[Ref1]** **[Ref2]** **[Ref3]**.

The measure of static bullet stability is the gyroscopic stability factor; Sg, which (in words) represents the ratio of *stabilizing* torque to *de-stabilizing* torque. If the ratio is greater than 1.0, the stabilizing torque is stronger than the de-stabilizing torque, and the bullet flies point first. If the ratio is less than 1.0, the opposite is true, and the bullet tumbles. In practice, you want the design Sg to be something greater than 1.0 to leave a margin for error. Values of Sg between 1.3 and 1.5 are often cited as minimum design values **[Ref1]** (I prefer 1.4). If the twist rate of the barrel is adequate, the bullet will be sufficiently stable, meaning

¹ This is not 'by design', it's a consequence of manufacturing tolerances.

Sg will be at least 1.4. What if the twist is faster? Is it bad to have too much twist? The answer is: it can be.

There are many factors that influence bullet dispersion which are related to spin rate. For example, *bullet imbalance and in-bore yaw will both cause groups to open up more for faster spinning bullets [Ref6]*. In other words, the faster the bullet is spinning, the more it will 'disperse' if it has flaws, or is misaligned in the barrel. Apparently, it pays to minimize the twist rate to the slowest possible value that will impart adequate stability. Shooters often ask about the 'optimal' twist rate, or the 'optimal' RPM range, but the fundamental measure of stability is the stability factor, Sg. You could say that whatever twist rate or RPM generates an Sg of 1.4 is the 'optimal' twist rate or RPM.

Having said all that, the penalties for running faster twist barrels are not necessarily catastrophic. The excessive twist can only exaggerate dispersion if there are imperfections in the balance or alignment of the bullet. *Given perfectly balanced and aligned bullets, the extra twist can't hurt precision.*

Personally, I think that too much is made of choosing the right twist to achieve the 'optimal' Sg. When you hear someone say that a particular combination of twist rate, velocity, bullet weight, etc resulted in 'remarkable precision', chances are, the twist rate was a small issue to it. If someone says that they have two barrels exactly alike, and the faster twist shot smaller groups, then there is necessarily something else behind the precision. Excessive twist can only hurt grouping ability. And if they say that the slower twist barrel shot better groups, then it *might* be due to the twist rate, or to something else.

There is another aspect of bullet stability that comes up from time to time. Some shooters hold the belief that over stabilizing bullets can harm the effective BC at long range. The reasoning is that if the bullet's too stable, it may fail to 'trace', meaning the nose won't follow the trajectory and will be flying at a 'nose high' angle for the last part of the flight. Flying like this increases the area presented to the oncoming air, and increases drag. I could tell you about numerous modeling and simulation results, and bore you with equations that show that over stabilizing bullets does not significantly affect the BC as described above, *but you already know it*. Think about how much elevation you put on your sights to be zeroed at 1000 yards. About 30 MOA is a good average. That's $\frac{1}{2}$ of one degree. On the downrange leg of the trajectory, the bullet may be falling at a little steeper angle, say 40 MOA, or $\frac{2}{3}$'s of one degree. So you can see that the angles involved are very small. Even for a bullet flying with excessive Sg, the nose will still 'trace' along the trajectory somewhat, but not as well as a bullet with a lower Sg. For the 180 grain VLD, flying at a 'nose high' angle of $\frac{1}{2}$ of one degree which is the most it will be launched with, *even if the bullet completely fails to trace*, it will only be flying at most 1 degree nose high during the end of the trajectory. This amount of 'nose high' flight results in the bullet presenting about 2% more area for drag to act on, which directly correlates to a 2% reduction in BC. Remember, this represents the maximum increase in drag that could occur from a bullet completely failing to trace, and it only applies to the last couple hundred yards of a long range trajectory. Furthermore, this example is for a bullet having a longer than average bearing surface, meaning it will suffer

the most (in terms of drag) from flying nose high. *For all practical purposes, there is no difference in **effective BC** for bullets due to various levels of Sg.*

Figures 3 and 4 are stability *maps* that show the gyroscopic stability factor of the 168 and 180 grain VLD bullets for various twist rates and combinations of muzzle velocity and air density. The point of having three lines on each stability map is to show how much stability is affected by the variables. The gray line at Sg=1.4 is the minimum recommended level of stability.

Berger 7mm 168 grain VLD Stability Map

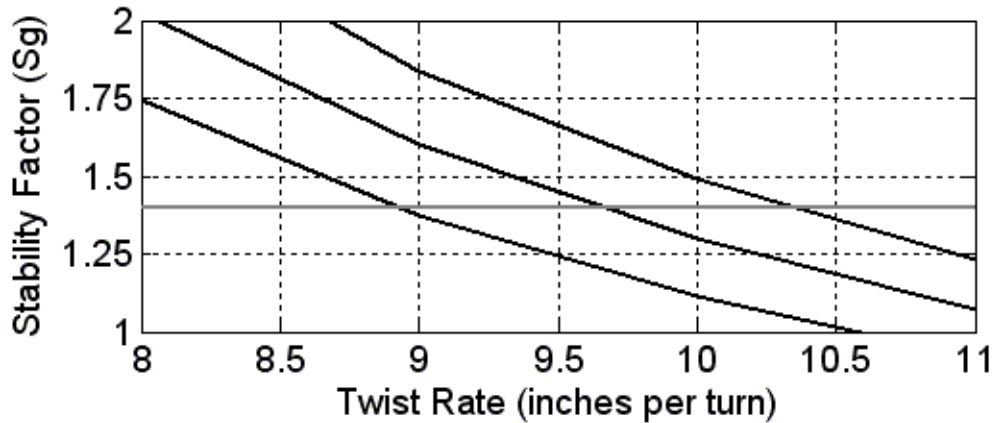

Twist rate	Sg (Worst case)	Sg (Nominal)	Sg (Best case)
1:8.0"	1.74	2.03	2.33
1:9.0"	1.38	1.60	1.84
1:10.0"	1.11	1.30	1.49
1:11.0"	0.92	1.07	1.23
Twist for Sg=1.4	1:8.9"	1:9.7"	1:10.3"

Figure 3. Stability map for 168 grain VLD.

The data in Figure 3 shows what Sg will result from various combinations of twist, velocity, and air density. Here are the conditions for the worst case, nominal, and best case scenarios:

- Worst case: 2600 fps, 0°F, 29.85" Hg, and 0% humidity.
- Nominal case: 2800 fps, 59°F, 29.53" Hg, and 50% humidity.
- Best case: 3000 fps, 100°F, 29.53" Hg, and 100% humidity.

The numbers in bold across the bottom of the table show the twist rate required to achieve Sg=1.4 in each set of conditions. The manufacturer recommended twist rate of 1:10" might produce an Sg as low as 1.11 in the worst combination of conditions. Remember this is still technically 'adequate' because it's greater than 1.0, but a twist of 1:9" would produce a more comfortable level of stability if you plan to shoot this bullet at 2600 fps at sea level in 0°F weather.

Berger 7mm 180 grain VLD Stability Map

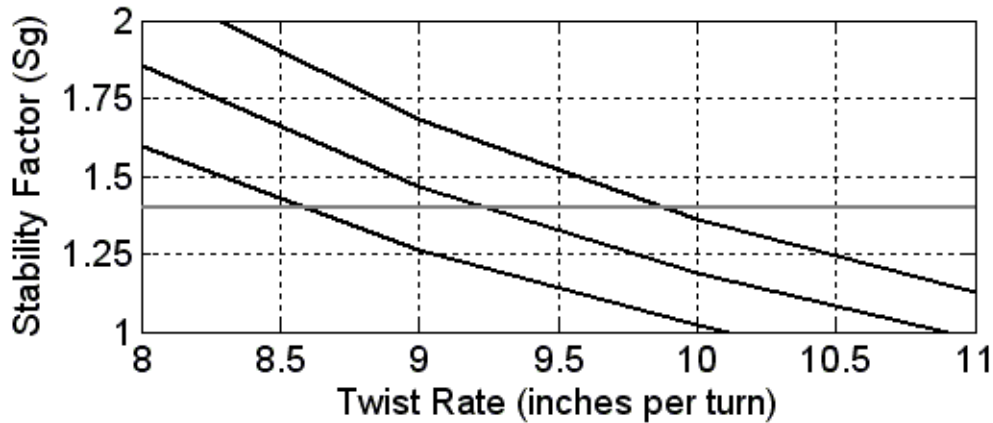

Twist rate	Sg (Worst case)	Sg (Nominal)	Sg (Best case)
1:8.0"	1.59	1.85	2.13
1:9.0"	1.26	1.47	1.68
1:10.0"	1.02	1.19	1.36
1:11.0"	0.84	0.98	1.13
Twist for Sg=1.4	1:8.6"	1:9.2"	1:9.9"

Figure 4. Stability map for 180 grain VLD.

Berger recommends a 1:9" twist for the 180 grain VLD. According to the stability map, 1:9" produces an Sg just over 1.4 in nominal conditions. In the 'worst case' conditions, Sg remains somewhat comfortable at 1.26. Most competition shooting is done in summer conditions closer to the 'best case' scenario that is marked by high temperatures and high humidity, which means decreased air density. If you're only shooting in the summer and you keep the bullet velocity up, you can almost get away with a 1:10" twist for this long bullet.

I'd like to publicly thank Don Miller for coming up with his highly accurate and simple to use twist rule. I believe it's truly the most original and important contribution to sporting arms ballistics in decades. All of the numbers in my stability maps are calculated with his terrific equations.

Ballistic Coefficient Testing

The 180 grain VLD is the bullet I shoot in competition (long range prone) and so it got a little more attention than the lighter 168 grain VLD in terms of number of shots tested. I've got data for 17 shots of the 180 grain VLD, and 5 shots for the 168 grain VLD. If the data is clean, 5 shots are typically all that's required to determine the BC with reasonable certainty. The 180 grain VLD was tested on two separate dates, 3 months apart. The first test included samples with the meplat trimmed, unmodified, and pointed. The data from the two test dates for the nominal meplat diameter agree within 1%. The 168 grain VLD was

only tested on one day, and only with unmodified meplat. Since the ogive design of the two bullets is the same, the effects of meplat trimming and pointing on the form factor of the 180 grain VLD can be projected on to the 168 grain VLD. By doing so, we can know the effects of modifying the meplat on the BC of the 168 grain VLD. Figures 5 and 6 show the results of the BC testing.

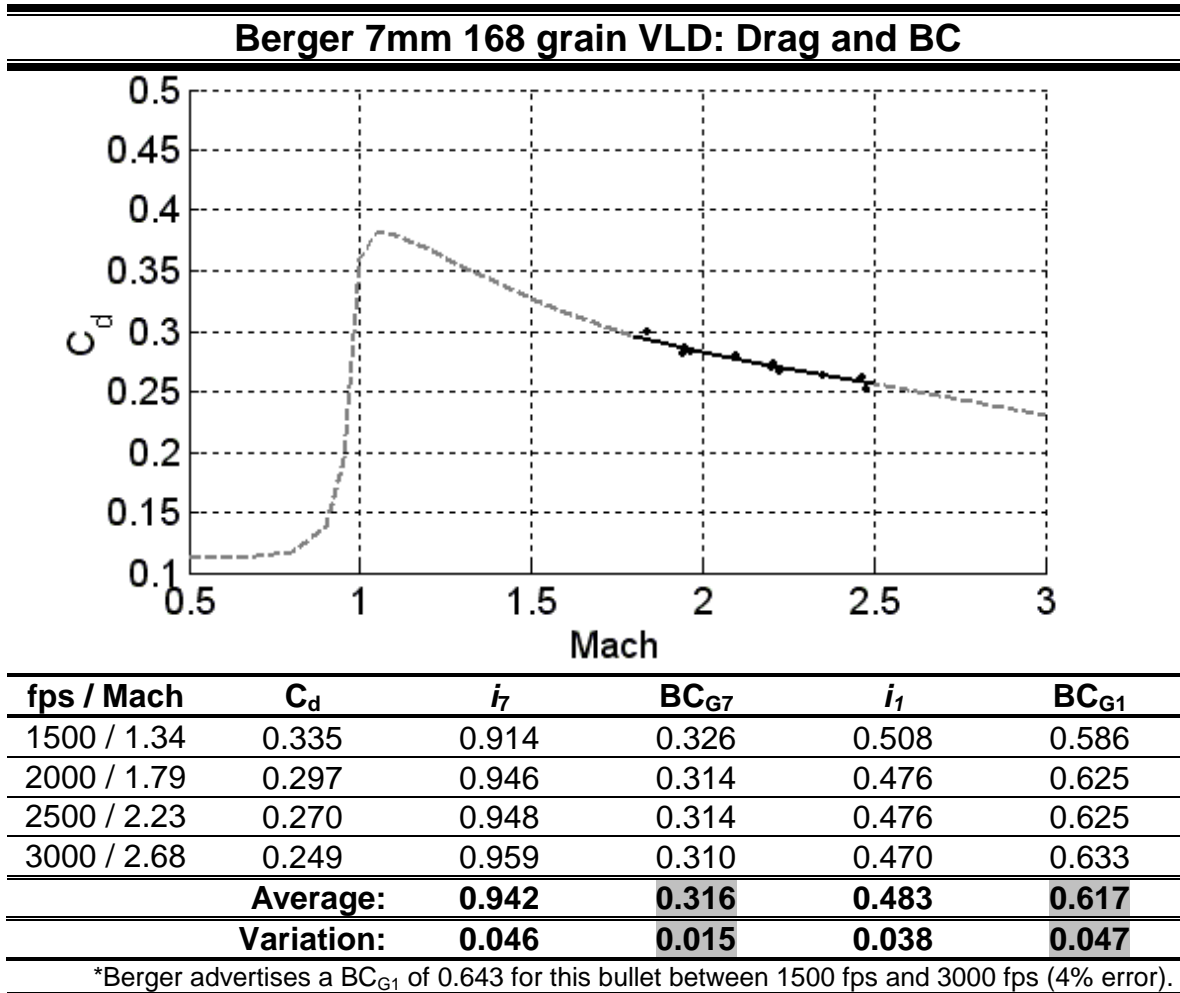

Figure 5. Measured drag coefficient, form factors and ballistic coefficients of the Berger 7mm 168 grain VLD.

The solid portion of the drag curve in Figure 5 is the velocity range that was actually tested for this bullet. The acoustic sensors were placed at intervals out to 600 yards for this test, and bullets were fired at both full and reduced charges to produce high and low velocity flight speeds, simulating longer range flight performance. The gray portion of the line is the drag profile of the G7 standard projectile.

According to the numbers in Figure 5, it appears that there is more variation of the G7 form factor (i_7) than the G1 form factor (i_1). Actually, the G7 *percentage* variation is less than the G1 *percentage* variation (4.9% variation for G7 vs 7.9% for G1) meaning that the G7 standard is a better fit for this bullet than the G1 standard.

Berger advertises a G1 BC of 0.643 lb/in² for this bullet. My measured G1 BC is 0.617 lb/in², which is a 4% error. Before you condemn Berger for inflating their advertised BC, you should know that 4% is an incredibly accurate estimate for a computer program. Such estimates typically have as much as +/- 10% error. See [Ref5] for a list of reasons why the advertised BC may be in error.

It is worth mentioning that the G7 form factor of 0.942 is the lowest form factor that I've measured for any bullet to date (I've tested over 40 bullets so far).

Berger 7mm 180 grain VLD: Drag and BC

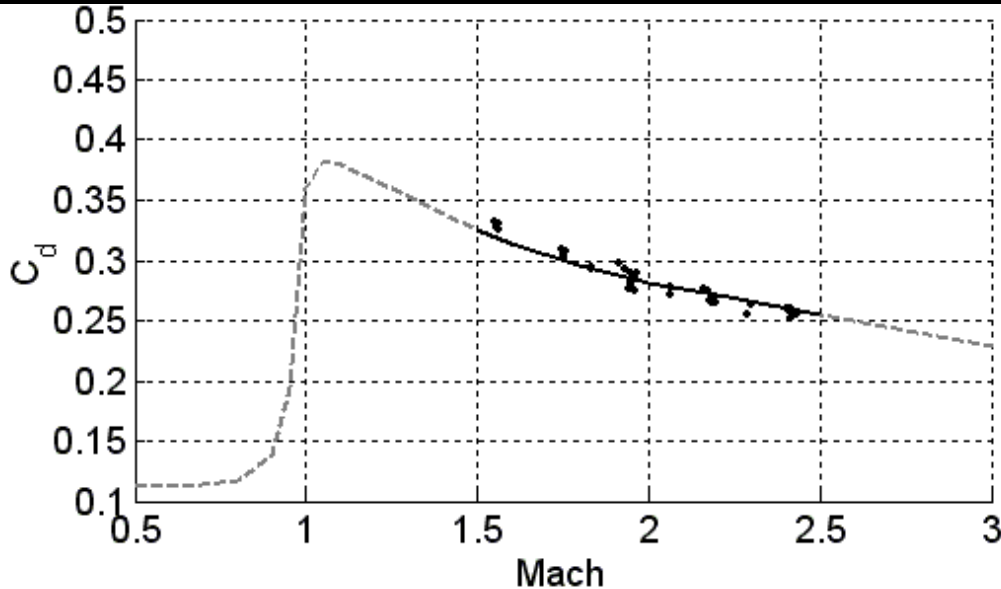

fps / Mach	C _d	i ₇	BC _{G7}	i ₁	BC _{G1}
1500 / 1.34	0.355	0.967	0.330	0.538	0.593
2000 / 1.79	0.301	0.962	0.331	0.484	0.659
2500 / 2.23	0.266	0.934	0.341	0.469	0.679
3000 / 2.68	0.239	0.921	0.346	0.451	0.706
Average:		0.946	0.337	0.486	0.659
Variation:		0.047	0.017	0.086	0.113

*Berger advertises a BC_{G1} of 0.684 for this bullet between 1500 fps and 2900 fps (4% error).

Figure 6. Measured drag coefficient, form factors and ballistic coefficients of the Berger 7mm 180 grain VLD.

You can see that Figure 6 is littered with data points over a wide range of velocities. This bullet has been tested out to 1000 yards multiple times, and the measured BC data has been consistent and repeatable. It's important to note that the data points shown in Figure 6 are only for the bullets with unmodified meplat. The 'scatter' in the data is due to my limitations in resolving and processing the acoustic test data, which is sometimes 'noisy'. Although some data scatter is visible, I have high confidence that my reported average BC's are very close to the actual BC's for these bullets.

In a previous section, we discussed the similarities in design between these two bullets, and suspected that the measured form factors would be very similar. You can see from Figures 5 and 6 that the measured form factors are indeed very close: 0.942 compared to 0.946. This match appears more impressive than it is, because my measurements aren't that precise! A more honest way to report the measured form factors is: 0.942 (+/-0.01) compared to 0.946 (+/-0.01). In light of the measurement tolerances, we can say that these two bullets have, for all practical purposes, the same form factor as expected from the design.

Since the form factors are the same, the difference in BC between these two bullets is entirely due to the greater weight (mass) of the heavier one.

Remember the equation for BC **[Ref4] [Ref6]**:

$$BC = \frac{weight / 7000}{i \cdot cal^2}$$

Where:

weight = bullet weight in grains

i = form factor (G1 or G7)

cal = bullet caliber in inches

Using the G7 form factor of 0.942 for the 168 grain VLD yields a G7 BC of 0.316 lb/in². I've decided to make a habit of including the units along with the BC just to promote an understanding of what the number actually is, which is sectional density divided by form factor. We can project the BC of the heavier bullet by simply multiplying the G7 BC of the lighter bullet by the ratio of weights, like this: 0.316 (lb/in²) * 180/168 = 0.339 lb/in². Using the actual measured form factor of the 180 grain VLD yields a G7 BC of 0.337 lb/in², which is a trivial difference.

Understanding the components of BC can be a powerful piece of knowledge. BC has traditionally been a mysterious and controversial number, but when it's used right, and referenced to the proper standard (G7 for long range bullets **[Ref5]**) it's really quite simple and predictable. For example, as shown above, the BC is calculated using sectional density and form factor. The sectional density is easy to figure, it's just the bullet weight (in pounds) divided by the caliber (in inches) squared. Now, to get BC, you just need the form factor. Form factors referenced to the G1 standard are not very intuitive for long range bullets, and they vary with bullet velocity. But using the G7 standard, form factors range from as low as about 0.94 up to about 1.12, and it's effectively a fixed number for that bullet, regardless of velocity. A bullet with the profile of the .30 caliber 155 grain Lapua Scenar has a form factor very close to 1.0 because that bullet is shaped very similar to the G7 standard projectile. In other words, the 155 grain Lapua Scenar is the 'nominal' G7 reference. Bullets that are more streamlined have a lower form factor, and vice-versa, but the range is pretty narrow; from 0.94 for very streamlined bullets to 1.12 for non-streamlined bullets. Given the above information and a hand calculator, you can actually *guess* at the form factor just by looking at a bullet's profile, and calculate a G7 BC that's possibly more accurate than the manufacturers advertised number! More and

more modern ballistics programs are offering the option to input BC's referenced to multiple standards including G1 and G7. For long range bullets, G7 is always the better option.

Now to answer the question posed earlier in this article about the accuracy of the advertised 0.684 lb/in² G1 BC of the 7mm 180 grain VLD. The measured G1 BC for this bullet was 0.659 lb/in², which is 4% error (the same error as the 168 grain VLD). Again, this is a small error.

Meplat (bullet tip) modifications

Effects of both meplat trimming and meplat pointing were tested for these bullets. For those not familiar with these procedures, here's a quick explanation.

Meplat trimming is the process of cutting the ragged bullet tips to a smooth, uniform diameter. The objective is to eliminate bullet to bullet variations in BC that are due to

	168 grain VLD		180 grain VLD	
	Meplat	BC _{G7} (lb/in ²)	Meplat	BC _{G7} (lb/in ²)
Trimmed ²	0.084"	0.309	0.097"	0.324
Nominal	0.068"	0.315	0.062"	0.336
	0.064"	0.316	0.059"	0.337
	0.060"	0.317	0.055"	0.338
Pointed	0.044"	0.323	0.039"	0.344

Table 1. Effects of trimming and pointing meplat. Numbers in Bold indicate meplat sizes that were actually tested.

inconsistent tips. The downside to meplat trimming is that it leaves the bullet tips slightly larger, which decreases the average BC a little. Meplat pointing is a newer treatment whereby the bullet is pressed into a die that has an insert at the top that 'squeezes' the bullet tip down in diameter. In this way, a large meplat can be made smaller. The net result is an increased and a more uniform BC. Table 1 shows the effects of trimming and pointing the meplat on the G7 BC of the two Berger bullets.

Next month, I'll take the results of this test data and put it into the context of 1000 yards slow fire prone shooting. The analysis will focus on the performance of these two bullets in terms of wind drift.

References

[Ref1] Don Miller, "The New Twist Rule: Part II: Examples, Stability Questions, and Other Estimation Methods" *Precision Shooting*, March 2008, pp 81-86

[Ref2] Don Miller, "The New Twist Rule Part I: Tests Against Experimental Data" *Precision Shooting*, February 2008, pp 73-78

[Ref3] Don Miller, "A New Rule for Estimating Rifling Twist: An Aid to Choosing Bullets and Rifles" *Precision Shooting*, March 2005, pp 43-48

² This represents an extreme amount of trimming. The large value is given to bound all possibilities, and show the consequences of excessive trimming.

[Ref4] Bryan Litz, "Understanding Long Range Bullets Part I: The Nature of Scale" *Precision Shooting*, May 2007

[Ref5] Bryan Litz, "Ballistic Coefficient Testing of the Berger .308 155 Grain VLD" *Precision Shooting*, March 2008

[Ref6] Robert L. McCoy, "Modern Exterior Ballistics" Schiffer Publishing, Ltd., Atglen, PA, 1998.