

# **Berger's 7mm VLD Bullets**

## **Part 2: Performance Analysis**

**Bryan Litz**  
**bsl135@yahoo.com**

### **Introduction**

Last month, Part 1 of this series focused on the fundamental design, stability characteristics, and Ballistic Coefficient testing results of Berger's 7mm bullets, both the 168 grain VLD and 180 grain VLD. This month, I'll be focusing on the analysis of those results, specifically in the context of NRA Long Range (1000 yard) slow fire prone competition. The focus of the performance analysis will be on the wind drift comparison between these two bullets.

### **Wind Drift is the Key Measure of Ballistic Performance**

There are many measures of ballistic performance to consider depending on the application. Kinetic energy and terminal performance are important for bullets intended for large game. A flat trajectory is important for shooting at unknown ranges. *These considerations are not relevant in the present analysis of long range target shooting.* Kinetic energy and terminal performance are a non-issue, because all we're doing is putting holes in paper. How much the bullet 'drops' on it's way to the target is also irrelevant because the range is known, and is the same for every shot. This leaves wind drift as the most important measure of *ballistic* merit for long range target shooting.

There are other factors of bullet performance that are relevant for long range target shooting like the precision, or grouping potential of the bullet. This is a combination of quality control for the bullet, as well as bullet/barrel fit, and reloading practices. The bullet you choose to shoot at long range is a compromise of many factors including recoil, barrel wear, precision, etc. *My current focus is only on the external ballistic performance of these bullets, and is only one of many things to consider when choosing a bullet.*



At the highest levels of NRA Long Range prone shooting, many things come into play. Most things like equipment and position can be mastered. Given 'no wind' conditions, most of the top shooters are able to clean (200/200) the long range target. When the wind blows, points begin to drop. The winners are the shooters who best manage the challenges presented by the wind, and drop the *fewest* points. There are many things involved in 'managing the wind'. The most important thing is the ability to judge the effects of the wind, and apply accurate corrections. Choosing equipment that has superior ballistics is only a way to 'lighten the load' on the task of shooting in the wind. No bullet, no matter how high the BC, will make it 'easy' to shoot high scores in tricky winds. But choosing equipment with strong ballistics can give you a slightly greater margin for error.

### **Slow and Heavy versus Light and Fast**

The two bullets under investigation exemplify a classic ballistic comparison. Will the extra speed of the lighter 168 grain VLD make up for it's

lower BC in terms of wind drift? This is definitely a loaded question! The key part to focus on is how much 'extra speed' will the lighter bullet have? To be fair, we will assume an equal level of muzzle *energy* for the two bullets, which implies equal chamber pressures for both. Note: this is NOT the same as using the same powder charge for both bullets. For this 'case study', I'll assume moderate pressure levels for a medium volume 7mm chambering: the .284 Winchester (long forgotten parent case of the popular 6.5-284). The .284 Winchester can comfortably propel the 180 grain VLD to 2800 fps in a 28" to 30" barrel. Given the same chamber pressure and kinetic energy at the muzzle (3130 ft-lb), the 168 grain VLD would achieve a velocity of 2898 fps, call it 2900 fps. Using these numbers, we can make a fair apples-to-apples comparison between the two bullets. Obviously, if we assumed equal velocities for both bullets, the heavier, higher BC bullet would come out on top but it wouldn't be a fair comparison. *You simply can't achieve the same velocity with a heavy bullet that you can with a lighter bullet with the same pressure and barrel length.* Performing the comparison with equal muzzle *velocities* (as is commonly done) wouldn't be a complete, or fair comparison. For example, if you compared both bullets at 2900 fps, this implies greater pressure and energy levels for the heavier bullet. If a cartridge can generate 2900 fps with a 180 grain bullet, it certainly can push a 168 grain bullet faster!

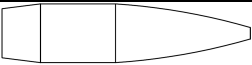
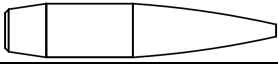
The resulting wind drift for these two bullets at their respective speeds are shown in Table 1. For comparison purposes, the .30 caliber 155 grain Lapua Scenar Palma bullet, which has a form factor very close to the G7 standard projectile, is shown for comparison.

Bullet	Velocity (fps)	i7	G7 BC (lb/in <sup>2</sup> )	Wind Drift
30 cal 155 gr Scenar 	3000	0.996	0.234	93.3"
7mm 168 grain VLD 	2900	0.942	0.316	64.2"
7mm 180 grain VLD 	2800	0.946	0.337	62.3"

**Table 1. Wind drift is for a 10 mph direct crosswind at 1000 yards in standard atmospheric conditions.**

It's interesting to note that the 155 grain Palma bullet at 3000 fps has almost as much muzzle energy as the .284 Winchester example (3095 ft-lb for the Palma vs. 3130 ft-lb for the .284). Granted, the Palma load is a considerably 'hot' load for the .308 Winchester, whereas the .284 load represents a more moderate charge.

Notice the relationship between the profile of the bullets and their form factors (i7). The longer nose of the 7mm VLD's is the main feature that drives the form factor down into the 0.94 area. Another way to view the form factor is to observe that the *drag coefficient* of a bullet with a G7 form factor of 0.94 has 94% of the standard projectile's *drag coefficient* at any speed [Ref2]. The form factor of the 7mm bullets is about 6% better than the form factor of the Lapua Palma bullet. However, the ballistic coefficient of the 7mm bullets is way more than 6% better. The reason why is because the sectional density of the 7mm bullets is

greater than that of the Palma bullet (refer to last month's article for the calculation of BC as a function of sectional density and form factor).

The wind drift numbers in Table 1 indicate that the 168 grain and 180 grain 7mm bullets exhibit about the same level of wind deflection when a fair (equal muzzle energy) comparison is made. Note that just because both bullets have the same kinetic energy at the muzzle, this *does not* imply equal recoil. Recoil is tied to conservation of momentum, which is all together different from kinetic energy. *The heavier bullet will generate more recoil when fired with the same muzzle energy than a lighter bullet.* The reason why has to do with the difference between kinetic energy and momentum, and is beyond the scope of this study. Just know that recoil is greater for the heavier bullet in this comparison.

So how significant is the difference in wind drift: 64.2" vs 62.3"? That's only 1.9" difference in a 10 mph crosswind at 1000 yards, which is 3%. Is that *really* enough to make a difference on the standard NRA Long Range target? How often are shots really that close to the line that the small difference in ballistic performance matters? In an attempt to shed some light on this question, we turn to modeling and simulation.

### **Modeling and Simulation**

So there is 1.9" difference in the wind drift of two bullets. How does that play out on the target over time? My objective is to simulate the firing of multiple 20 shot, 1000-yard slow fire prone matches. For those who remember the comparison of Palma bullets made a couple months ago [Ref1], this approach will be very similar, with a few exceptions. In order to thoroughly investigate the impact of a 1.9" difference in wind drift on the 1000 yard target, I'll model three different scenarios intended to represent various levels of shooter skill. The first comparison will be made assuming a 'novice' shooter with a below average hold, and below average ability to read wind conditions. The second scenario will be for an 'average shooter' with an average hold and an average ability to call wind. The final comparison will represent an 'elite shooter' with a stellar hold, and the ability to call wind nearly perfectly.

### **Performance Comparison for the Novice Shooter**

So how do we model the 'novice' shooter? We all may have different criteria for describing the abilities of a 'novice'. I have in mind the typical beginner shooter, possibly classified Marksman or Sharpshooter. I chose the following set of abilities: The Novice shooter's equipment and hold are barely good for a ten ring (20") sized group at 1000 yards in 'no wind' conditions. He can judge the effect of a crosswind within +/- 5 mph 95% of the time<sup>1</sup>. I'm assuming there is sufficient wind to make a +/- 5 mph error possible. What kind of scores will the novice shooter produce given his abilities, and the three bullets

---

<sup>1</sup> This means that the standard deviation of wind estimation error is 2.5 mph. (+/- 2 standard deviations give you a 95% confidence interval.) A normal distribution is assumed for the wind estimation error. This simply insures that extreme error is less likely than mild error.

in Table 1? Figure 1 shows three ‘virtual’ targets that characterize the likely performance of the novice with the three bullets.

Figure 1 shows that for the novice, there is effectively no difference between the two 7mm bullets. In fact, over the course of 20 simulated matches, the 168 grain VLD’s actually produced a higher average score by 1 point. This

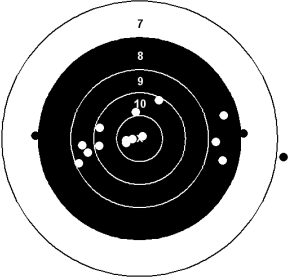
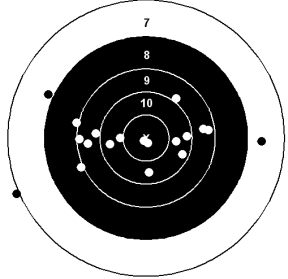
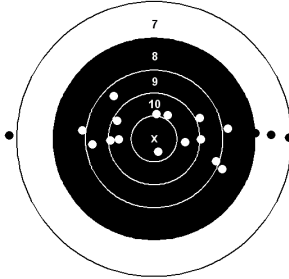
Novice Shooter		
Palma	168 grain VLD	180 grain VLD
 <p>*3 misses ‘off paper’</p>		
Average Score: 149-2X	Average Score: 175-4X	Average Score: 174-7X
<p>Figure 1. The graphics shown represent a typical target shot by a novice for the different bullets. Average score is a result of simulating the ‘virtual match’ 20 times. For reference, the 10 ring is 20” in diameter.</p>		

goes to show that for the novice shooter, the small benefit of the higher BC bullet is unnoticeable, there’s just too much ‘scatter’ for the small difference to affect anything. There is, however, a clear difference between the novice shooting the Palma bullet compared to the 7mm bullets. The average score for the higher BC 7mm bullets is 25 to 26 points higher for the higher BC bullets. The novice shooter, as modeled, suffers a few misses on average with a Palma rifle in tough winds.

### Performance Comparison for the Average Shooter

I’ll characterize the *average* shooter as an expert to master level shooter who has the ability and equipment to shoot a 15” group in no wind conditions.

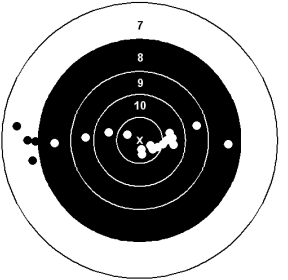
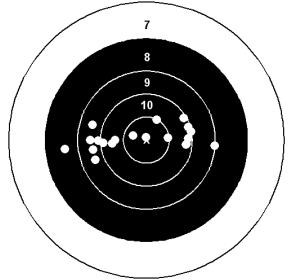
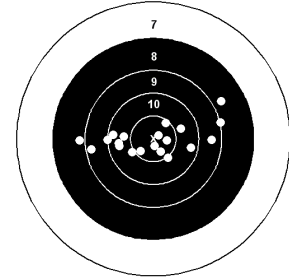
Average Shooter		
Palma	168 grain VLD	180 grain VLD
		
Average Score: 179-5X	Average Score: 191-7X	Average Score: 191-7X
<p>Figure 2. The graphics shown represent a typical target shot by an average shooter for the different bullets. Average score is a result of simulating the ‘virtual match’ 20 times. For reference, the 10 ring is 20” in diameter.</p>		

The average shooter is able to call wind within +/- 3 mph of its true value 95% of the time. Figure 2 shows the simulated results of virtual targets fired by an average shooter, using the same bullets as the novice shooter above.

Once again, the average shooter does significantly better with the higher BC 7mm bullets than with the Palma equipment. Also, just like for the novice shooter, *the average shooter does not benefit from shooting the 180 grain VLD's compared to the 168 grain VLD's*. For the average shooter, there is still too much 'scatter' for the small benefit of the higher BC to make a practical difference. We are focusing on two specific 7mm bullets here, but this basic analysis can be applied to any two bullets that are very close in wind drift. The bottom line is that the small difference just doesn't show up in the score. This analysis is specific to the target. In other words, *a target with smaller scoring rings like the F-class or Benchrest targets will reflect a slight ballistic advantage more clearly than a target with larger scoring rings*.

Well, we've shown that both novice and average shooters can't really tell the difference in the wind drift of the two bullets. What about the 'elite' shooter?

### Performance Comparison for the *Elite* Shooter

I'll describe the 'elite' shooter as someone capable of shooting a 10" group in no wind conditions. In other words, if the group is perfectly centered, the elite shooter will just be able to break the existing long range (any-sight) record of 200-19X in no wind conditions. The *elite* shooter is able to judge the crosswind speed within +/- 1 mph for 95% of his shots.

As you can see, even for the elite shooter, the minor ballistic advantage of the slower, higher BC bullet is minimal even after averaging 20 'virtual matches'. Running the set multiple times, I was able to produce averages that slightly favored the 168 grain VLD, but in the long run, the 180 VLD has a very slight advantage, even if it can only be detected by elite shooters.

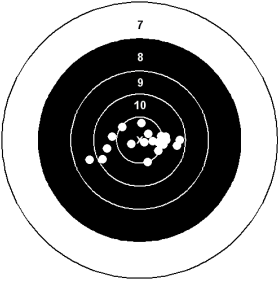
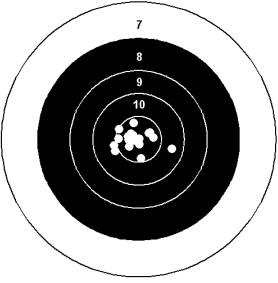
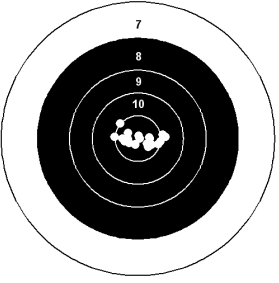
<b>Elite Shooter</b>		
<b>Palma</b>	<b>168 grain VLD</b>	<b>180 grain VLD</b>
		
Average Score: 199-13X	Average Score: 200-15X	Average Score: 200-16X

**Figure 3.** The graphics shown represent a typical target shot by an elite shooter for the different bullets. Average score is a result of simulating the 'virtual match' 20 times. For reference, the 10 ring is 20" in diameter.

Modeling and simulation can be risky business, both for the person *doing* the modeling, and for the person looking at the results. For both sets of people, it's important to understand the limitations and scope of the study. The modeling and simulation I'm presenting here is only focused on the external ballistic performance of the bullets in the specific application of long range, NRA shooting. My simulation doesn't capture the effects of: loose slings or sights, slam fires, rain, sweat and/or sand in your eyes and lenses, heat exhaustion, fire ants, stuck casings, or cease fires for 'boats in the impact area'. All of these and many more are real problems for long range prone shooters that affect scores. The intent of my modeling is to focus in on one aspect; *wind drift*, and isolate its effects on scores for different bullets. This is something that's hard to do in the real world which is why it can be hard to tell how many dropped points were for wind, and how many were caused by other things. The business of looking at 'virtual matches' is an academic exercise intended to put the basic wind drift numbers into the context of a specific shooting scenario for a specific target. With this in mind, we'll again use the 'virtual match' approach to look at the effects of meplat trimming and pointing.





### **Possible Effects of Meplat Modifications on Score**

We'll perform this analysis in the same way as the previous one. This time we'll leave the Palma bullet out of it and focus on the 7mm bullets. Table 2 shows what affect the meplat modifications may have on wind drift and score due to differences in ballistic performance. This is a good opportunity to point out a limitation in this particular simulation. The reason why meplat trimming is done is to uniform the BC of the bullet, thereby minimizing vertical dispersion due to variations in BC. My simulation does not give the trimmed meplat bullets less vertical dispersion. This is a shortfall of this particular simulation. In order to model that effect, it would be necessary to measure the meplat of all the bullets in a box to see what the range of diameters is, and how much vertical dispersion they would cause. Then the simulation could be rerun with that much less vertical dispersion for the trimmed and pointed meplats. As it stands, there are some accurate and valuable conclusions that can be drawn from the results of the virtual matches in spite of its shortcomings.

- High BC bullets will not enable a novice shooter to produce high master scores. The scores that are attainable by the shooter are tied to that shooters ability to hold, squeeze, and read wind more than small differences in ballistic performance of the bullets.
- The small benefit of a slightly higher BC does not greatly impact the score on the long range NRA prone target, even for elite shooters.

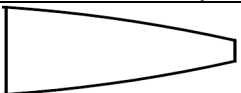
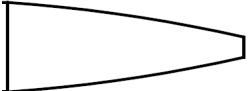
Understand that these results are specifically tied to long range prone shooting on the NRA Long Range prone target. For targets having smaller scoring rings (F-class for example), the small difference in ballistic performance may show up as a greater difference in the score.

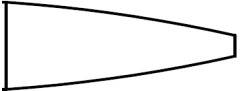
One item to note is that the scores of the Novice show a little improvement as the wind drift is reduced. This is not as prevalent for the average and elite shooter. I can offer two explanations for this. Either the trend is a statistical anomaly made possible by the excessive scatter of the shots, or the trend is real. If the trend is real, it's probably because the more scattered hits all over the paper are *closer to more scoring rings*. In other words, for a good group, you only have 1 or two scoring rings to encounter that could affect the score (edge of the X and 10 rings). However, when the shots are scattered all over the paper, there are more boundaries for *slightly inside* shots to benefit from.

Bullet		Ballistic Parameters			Results		
Meplat	7mm 168 grain VLD at 2900 fps	i7	G7 BC (lb/in <sup>2</sup> )	Wind Drift	Novice	Ave	Elite
Trimmed 0.068"		0.944	0.315	64.3"	173-5	190-6	200-15
Nominal 0.064"		0.942	0.316	64.2"	175-4	191-7	200-15
Pointed 0.044"		0.921	0.323	62.2"	176-4	190-7	200-17
Meplat	7mm 180 grain VLD at 2800 fps	i7	G7 BC (lb/in <sup>2</sup> )	Wind Drift	Novice	Ave	Elite
Trimmed 0.062"		0.949	0.336	62.5"	173-4	191-7	200-16
Nominal 0.059"		0.946	0.337	62.3"	174-7	191-7	200-16
Pointed 0.039"		0.927	0.344	60.7"	175-4	192-7	200-16

**Table 2. Wind drift is for a 10 mph direct crosswind at 1000 yards in standard atmospheric conditions. The results are obtained by simulating 20 virtual matches for each combination of bullet and shooter.**

### Effect of BC on Drop

This is not especially important to known distance target shooting, but is a general interest item. The measured BC was 4% lower than advertised for both these bullets. How much error does that introduce into a drop calculation? For example; I'm shooting the 7mm 180 grain VLD at 2800 fps at 1000 yards, and I want to know how much the bullet drops. Using the advertised G1 BC of 0.682 lb/in<sup>2</sup>, I would calculate -288.4" of drop<sup>2</sup>. The measured G7 BC of 0.337 lb/in<sup>2</sup> results in a predicted -290.9" of drop. So in this case, the small error in advertised BC results in 2.5" (one ¼ MOA click) of error in predicted drop, which is negligible for target shooting. For the 168 grain VLD at 2900 fps, the drop

<sup>2</sup> sea level standard atmosphere

predicted with the advertised G1 BC of 0.643 lb/in<sup>2</sup> is -274.1". Using the measured G7 BC of 0.316 lb/in<sup>2</sup>, the predicted drop is -277.3"; a 3.2" error which is, again, negligible for long range target shooting.

Pointing the meplat of the 180 grain VLD results in the bullet hitting 3.0" higher at 1000 yards, 3.3" for the 168 grain VLD. Remember that these statements are specific to these bullets, and the amounts of pointing shown in Table 2. Results will vary for different bullets and amounts of pointing. Being very high BC bullets, these bullets will not be as affected, in terms of difference in vertical impact, by pointing the meplat. In other words, *lower BC bullets will show more difference in vertical point of impact than higher BC bullets when pointed the same amount.* As an example of this, the Berger .30 caliber 155 grain VLD from the March issue of Precision Shooting had a G7 BC that went from 0.228 lb/in<sup>2</sup> for the nominal 0.070" meplat, to 0.237 lb/in<sup>2</sup> for meplat pointed to 0.053". The difference in BC results in the pointed bullet hitting 10.7" higher than the unpointed bullet at 1000 yards.

## Conclusions

I've test fired the Berger 7mm VLD bullets and measured the BC to be on average, 4% lower than the advertised value for both the 168 grain and 180 grain weights. This small discrepancy is an expected, and acceptable margin of error for a computer predicted, advertised BC.

Wind drift is the most important measure of (external) ballistic merit for long range target shooting at known distance. *In order to perform a fair ballistic comparison of wind drift between the two bullets, the muzzle velocity of the heavier bullet has to be less than the lighter bullet.* The velocity was scaled by setting the kinetic energy equal at the muzzle, which is the same as assuming equal average chamber pressure. Only in this way can a completely fair comparison be made between bullets of different weight. The heavier, higher BC bullet going slower has a slight ballistic advantage over its lighter counterpart. However, the advantage is immaterial for novice and average shooters. It's even questionable if elite shooters are able to capitalize on the tiny ballistic advantage of the heavier bullet.

The analysis focused on prone shooting with the NRA long range target. It's quite possible that the same analysis done for F-class shooting on F-class targets with their smaller scoring rings would have resulted in different conclusions. Smaller scoring rings are less forgiving, and could possibly 'resolve' a performance difference measured in points, between these two bullets.

It was found that the 4% error in advertised G1 BC was insignificant to the predicted vertical impact of the bullet, even at 1000 yards.

As far as ballistic performance and its relationship to scores fired on the NRA Long Range Prone target, we can say the following:

- If there is a *significant difference* in ballistic performance, as in the comparison between Palma equipment and 'any rifle class' high BC equipment, then a difference in score due to ballistic performance is very profound.

- If the difference in ballistic performance is *small*, like ~2" of wind drift in a 10 mph crosswind at 1000 yards, then it is unlikely to greatly affect scores fired on the NRA Long Range Prone target for shooters of any skill level.

In the following months, I'll continue to investigate the effects of ballistic performance on long range shooting. Between Palma equipment and super high BC bullets is a gradient of ballistic performance to be studied. Furthermore, I'll investigate the effects of ballistic performance on targets other than the NRA Long Range Prone target with its large scoring rings. A target with smaller scoring rings can effectively *measure* ballistic performance (as well as shooter and equipment performance) with greater resolution.

### **References**

**[Ref1]** Bryan Litz, "Ballistic Coefficient Testing of the Berger .308 155 Grain VLD" *Precision Shooting*, March 2008

**[Ref2]** Robert L. McCoy, "Modern Exterior Ballistics" Schiffer Publishing, Ltd., Atglen, PA, 1998.