

Ballistic Coefficient Testing of the Berger .308 155 grain VLD

Bryan Litz

Introduction

The purpose of this article is to discuss the ballistics of the Berger .30 caliber 155 grain VLD as measured by firing tests. Such thorough and precise firing tests are a rare commodity for the sporting arms industry. As tempting as it is to dive into the interesting topic of the test itself, only limited discussion is provided on the actual test procedures. The main focus will be on the results of the tests.

So why go to the effort of measuring ballistic coefficient (BC) when the manufacturer provides it for us? The short answer is: because the manufacturer's advertised BC is often inaccurate. Most manufacturers use some kind of computer program to predict the BC. Few manufacturers actually test fire their bullets to get BC, and when they do, test methods vary between manufacturers.

The various methods used by the bullet manufacturers to establish BC's makes it very hard to compare bullets of different brands. This inconsistency has resulted in much confusion over the years to the point that many shooters give up on the notion that BC is a useful number at all!

Apparently, it would be a great benefit to the shooting community to have a single, unbiased third-party applying the same testing method to measure the BC of all bullets, and that is my motivation. Armed with truly accurate BC's, match shooters will finally be able to compare 'apples-to-apples' when choosing a bullet to use in windy competitions. Hunters will be able to calculate more accurate drop charts and will hit smaller targets in fewer shots at longer ranges. BC is an incredibly useful number, when it's used right.

Testing Procedure Overview

The basic idea of the test is to measure the bullet's time of flight at several (3 to 5) points as it flies down range. Then a specially adapted ballistics program is used to find out what BC results in the measured times of flight.

Acoustic sensors and wireless transmitters are used to detect the 'crack' of the bullet's supersonic passage, so this testing method only works on the portion of the bullet's trajectory that's supersonic. The downrange location of the sensors must be known to within one foot in order to minimize error, so a 300' tape measure and laser rangefinder are used to place the sensors in 200 yard intervals. Also, the vertical distance from the bullet's flight path to the sensors must be known within 1 foot so that the time lag of the sound traveling from the bullet to the microphone can be accounted for. Muzzle velocity must be known to a high degree of certainty so 8' screen spacing is used with an Oehler Model 35 chronograph, which results in no more than +/- 3 fps of error in velocity measurement.

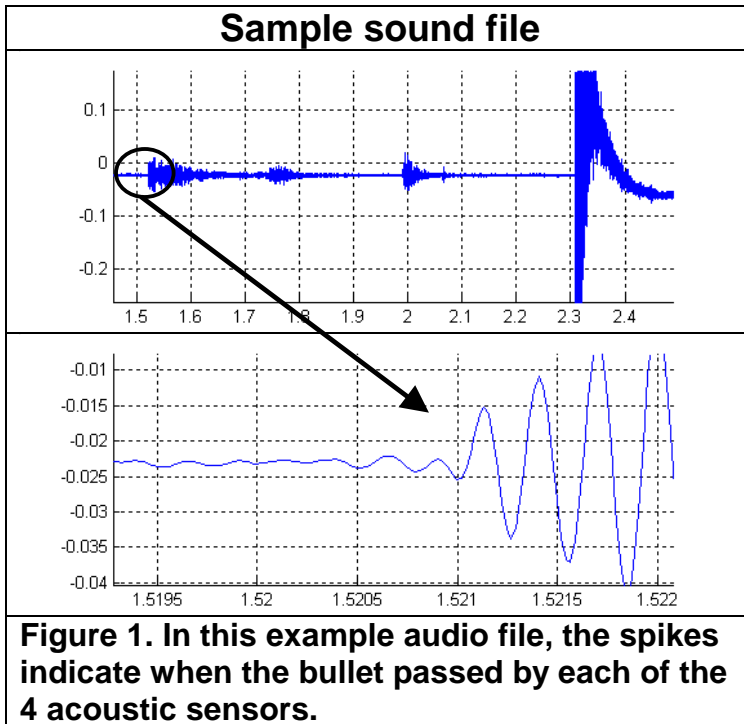

The end result of the testing is a sound file for each round fired showing spikes in 200 yard increments from muzzle to target. The times associated with the spikes are read into a custom ballistics program designed to iterate on BC until the predicted times of flight match the measured data. The benefit of using multiple times of flight instead of just total time of flight is that one can determine how the BC changes with velocity as the bullet flies downrange. When this is known, a

more appropriate standard can be chosen for calculating BC (for example G7 vs G1; more on this later).

There are many details of the test procedure left out as the focus of this article is on the results and not the testing methods. Suffice it to say that whenever all of the uncertainties involved in the test are added up, the BC can be determined to within +/- 1% of it's actual value. This statement is backed up by the fact that I have tested the same bullet on different days, at different ranges, under different conditions, with the sensors at different intervals and the measured BC is always measured less than 1% different each time.

On to the results

Due to manufacturing inconsistencies that exist for all brands of bullets, a drawing is provided showing the dimensions of the bullet that was tested. This allows shooters to see if there is any difference between the dimensions of their lot of bullets, and the lot of bullets that was tested. Figure 2 is a dimensioned drawing of the sample bullets that were tested.

The most likely difference among lots of the same bullet that has the biggest impact on BC is the meplat (bullet tip) diameter. In a later section, there is a chart that allows BC to be determined for different size meplat.

All of the information in Figure 1 is pretty self explanatory except for the Rt/R number. This ratio goes from 0 to 1 and is a measure of how 'pointy' the bullet ogive (nose) is. Mathematically, it's the ratio of: the radius of a tangent ogive to the radius of the specific bullet ogive for the same length nose. So if the bullet has a tangent ogive, then $Rt/R = 1.0$. If the ogive is a straight cone, then Rt/R is 0.0. In other words, Rt/R is a measure of how 'VLD like' the bullet ogive

is. The lower the number, the more like a VLD and vice versa. This bullet has a Rt/R of 0.51 which is about as low a number that's found on bullets.

Berger .30 cal 155 grain VLD

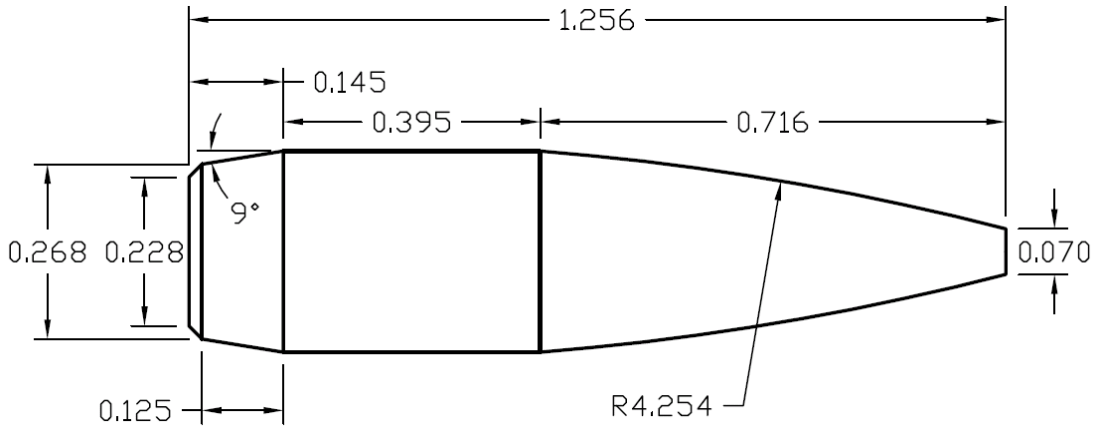

Dimensions taken from Lot#717

Bullet Properties	Test Equipment
Sample Size: 30 Weight: 155 grain Ogive Radius: 15.0 calibers Rt/R: 0.51	Velocity range: 3000 fps-1350 fps Barrel: Krieger Twist rate: 1 turn in 13 in Bore/Groove: 0.298"/0.307"

Figure 2. Bullet dimensions, properties, and test equipment.

The next concept I'd like to introduce before presenting the results is the idea that BC depends on velocity. If you look at the way Sierra advertises BC, they give different BC depending on the velocity of the bullet. Why is that? Well when you think about what BC is, it's just a comparison between the drag of a bullet to the drag of some standard bullet¹. If the drag of your bullet changes with velocity *differently* than the standard, then the BC is not constant, and must be described piecewise in velocity. This velocity dependence is very troublesome and has been the cause of much confusion.

If the velocity dependence of BC is known, then it can be accounted for, and you can compare bullets fairly and calculate accurate trajectories. What's even better than managing the problem is minimizing it. You can minimize the effect of velocity on BC by simply using a standard that is more like the actual bullet being tested.

Figure 3 shows drag curves for 3 projectiles. It's not important to understand exactly what Cd, or Mach number is. This figure is provided as a visual comparison of drag functions. The gray line represents the velocity dependant drag of a typical long range bullet. The top line is the drag curve of

¹ That's actually the definition of form factor. Ballistic coefficient is directly proportional to form factor.

the G1 standard that we use to calculate BC. The bottom drag curve is for the G7 standard which is much more similar in shape to the bullets we use. Rhetorical question: What standard (G1 or G7) would you say better matches the typical long range bullet? You can tell either by looking at the projectile shape itself, or by the drag curve that the G7 standard is a better match.

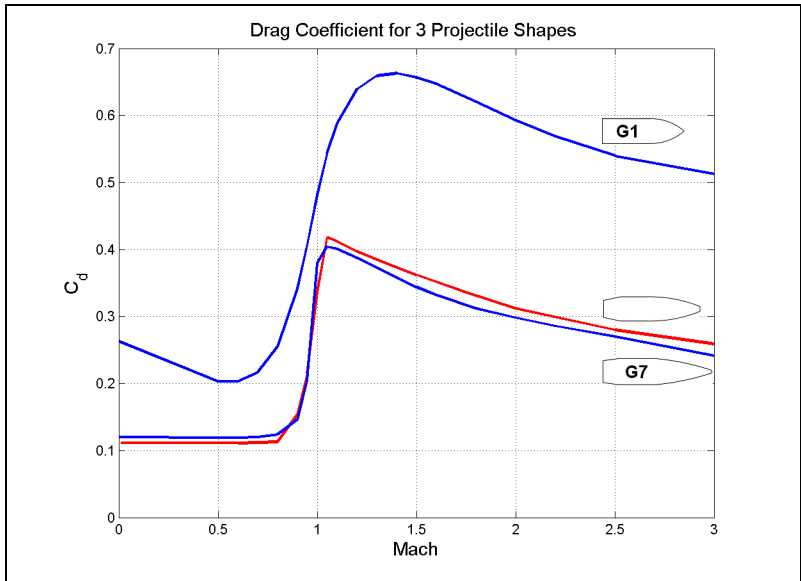

Mach	C_d	G1 Standard			G7 Standard		
		C_{d1}	i_1	BC_1	C_{d7}	i_7	BC_7
2.5	0.28	0.54	0.52	0.45	0.28	1.04	0.22
2.0	0.31	0.59	0.53	0.44	0.31	1.06	0.22
1.5	0.36	0.65	0.55	0.42	0.36	1.01	0.23
1.2	0.39	0.64	0.62	0.38	0.39	1.00	0.23
Variation:			0.10	0.07		0.05	0.01

Figure 3. Velocity dependence of drag for 3 projectiles.

The table of numbers provided in Figure 3 shows the variation of form factor² (i) and BC for both the G1 and G7 referenced BC's. The G1 BC varies from .38 to .45, while the G7 BC varies from .22 to .23. The fact that the G7 BC is lower than the G1 BC shouldn't trouble you. It's still the same bullet! The G7 BC is simply a better-matched standard to use for long-range bullets. If you want to calculate a trajectory with a G7 BC, you just have to tell your program that you're giving it a G7 BC and it works just fine.

It's no wonder we have a hard time comparing bullets BC when using the G1 standard. If I asked you what the BC is of the bullet in figure 3, you'd have to ask: for what speed? If we're dealing with G7 referenced BC's, you can simply answer .22 or .23 with little consequence.

It's important to understand that BC depends on velocity because that's what forces a proper test to have multiple sensors for time of flight. If you tried to measure BC using only two points (time of flight or velocity points), you have the BC that's only valid for one speed band. This is why my tests use multiple time of flight points; so the exact shape of the drag curve can be determined at all bullet speeds.

Figure 4 shows the drag coefficient that was measured for the Berger .30 caliber 155 grain VLD. Each cluster of points on the plot represents the actual test points that were measured. Similar to Figure 3, Figure 4 includes a chart of numbers showing the form factor (i) and BC referenced to both the G1 and G7

² Form factor (i) is the ratio of a bullets drag coefficient to the standard bullets drag coefficient at some speed.

standards. You can see that the G7 BC has less than 2% variation between 1500 fps and 3000 fps whereas the G1 BC has over 12% variation.

One big item of interest is how the measured BC compares to the advertised BC. In this case, Berger advertised a BC of .472 and .445 was measured (a 6% difference). Before condemning Berger of inflating BC's, consider the following points.

- The BC provided by Berger is the result of running a computer prediction program. Typically, such prediction programs are within +/- 10%.
- Berger's BC is an average from 1500 fps to 3400 fps which is the expected operating range of the bullet. This velocity range is different than what I happened to use (1500 to 3000 fps) which would result in the average being swayed up.
- The meplat (tip diameter) of the bullets I measured were slightly larger than other lots of this bullet that I've measured. This would cause me to measure a BC that's lower than average for this bullet.

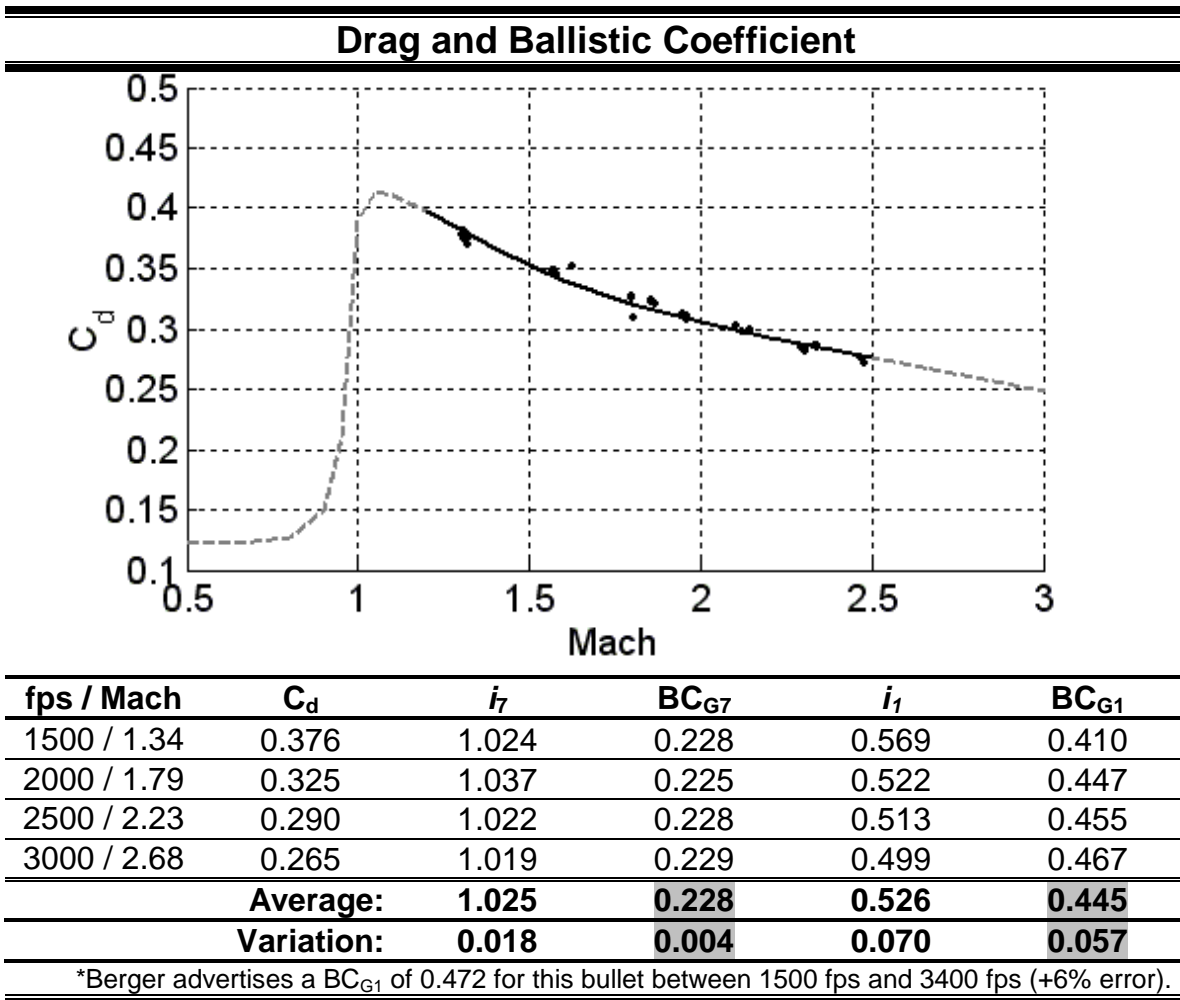

Figure 4. Drag and ballistic coefficient

I'm making these points to clarify that just because a manufacturer advertises a BC that's higher than measured, it doesn't mean it was intentionally inflated. There are many reasons for the actual BC to differ from what's

advertised. In the big picture, 6% is actually very close for a computer predicted BC value.

Meplat (bullet tip) modifications

Effects of both meplat trimming and meplat pointing were tested for this bullet. For those not familiar with these procedures, here's a quick explanation. Meplat trimming is the process of cutting the ragged bullet tips to a smooth, uniform diameter. The objective is to eliminate bullet to bullet variations in BC that are due to inconsistent tips. The downside to meplat trimming is that it leaves the bullet tips slightly larger, which decreases the average BC a little. Meplat pointing is a newer treatment whereby the bullet is pressed into a die that has an insert at the top that 'squeezes' the bullet tip down in diameter. In this way, a large meplat can be made smaller. The net result is an increased and a more uniform BC.

So *how much* does trimming reduce BC? *How much* does pointing increase BC? *How much* BC variation is in a box of bullets due to non-uniform meplat? Table 1 provides the answers to these questions for the Berger 155 grain VLD. Using Table 1, you can interpolate the BC for bullets having meplat diameters between 0.053" and 0.087". Numbers that appear in bold in Table 1 are meplat diameters that were actually tested. The other values are projected based on test results.

Meplat diameter	BC _{G1}	BC _{G7}	
Trimmed ³	0.087"	0.428	0.219
Nominal	0.074"	0.441	0.226
	0.070"	0.445	0.228
	0.066"	0.449	0.230
Pointed	0.053"	0.462	0.237

Table 1. Effects of trimming or pointing meplat. BC's are average from 1500 fps to 3000 fps.

Conclusion

So how can we put the results to use? Well, let's start by seeing how much trajectory error results from using the advertised BC compared to the measured BC. Table 2 shows some 1000-yard flight metrics for this bullet fired at 3000 fps in a 10 mph wind in standard atmospheric conditions. Since the G7

	Advertised	Measured	
BC	BC _{G1} = .472	BC _{G7} = .228	BC _{G1} = .445
Drop	-309"	-320"	-324"
Wind drift	90"	97"	98"
End velocity	1342 fps	1252 fps	1279 fps
Time of flight	1.511 S	1.548 S	1.554 S

Table 2. 1000-yard flight metrics calculated using different BC.

BC showed the least variation with velocity, we can consider it to be the 'truest' BC, and compare the others to it. If you used the *advertised* BC to

calculate the trajectory, there is an error of -11" in drop, -7" in wind drift, +90 fps in velocity, and -0.037 seconds in time of flight at 1000 yards. Likewise, if you used the *measured* G1 BC to calculate the trajectory, the errors are: +4" of drop, +1" of wind drift, +27 fps of remaining velocity, and +0.006 seconds time of flight. One thing you might notice when comparing the measured G1 BC results with the G7 BC results is the following contradiction: The G1 BC results in more drop, more drift, and longer time of flight, BUT predicts a higher remaining velocity!

³ This represents an extreme amount of trimming. The large value is given to bound all possibilities, and show the consequences of excessive trimming.

This result is a consequence of the poor match between the test bullet and the G1 standard.

OK, so there's 11" of error in drop, and 7" error in wind drift at 1000 yards between the advertised BC and the measured BC. Who cares? Most rifles aren't accurate enough to notice the difference. I'll tell you who cares: Palma shooters. As a 155 grain, .30 caliber bullet, this projectile meets the requirement for international Palma competition. Most major bullet makers produce a 'Palma' bullet in .30 caliber, weighing 155 grains. When making a decision about what bullet to choose for Palma competition, shooters carefully compare the BC's of all the available bullets because BC will determine how much wind drift the shooter has to deal with. Maximize BC, and wind drift is minimized, resulting in fewer points dropped for wind. For example: If bullet 'A' drifts 90" in a 10 mph cross wind and bullet 'B' drifts 97" in the same wind, the shooter has a greater margin of error with bullet 'A'. The problem is that advertised BC's vary based on the methods used to create them, which are different for all bullet makers. This makes it very hard to make an 'apples-to-apples' comparison. My intent is to provide shooters with measured BC's for bullets from all manufacturers. Not being a bullet maker myself, and using the same repeatable test methods for each bullet, I am able to provide *accurate* and *unbiased* ballistic coefficient data to the shooters who need it.

In the next several months, I'll feature other .30 caliber, 155 grain bullets that are used in international Palma competition. Comparisons will be made between all the bullets. Since they're all .30 caliber, and all weigh 155 grains, the sole feature that separates these bullets is the form factor (shape). When the series concludes and all the Palma bullets are compared, shooters will have the ability to make true 'apples-to-apples' comparisons of Palma bullets based on rigorous, non-biased scientific testing.

If these articles generate enough interest to continue after that, I will publish test results on bullets used in other types of shooting where BC is important, for example varmint and big game hunting and long range benchrest shooting. So if you find this information valuable, and would like to see the series continue, please give your feedback to the editor or myself.